

DOUBLE RING

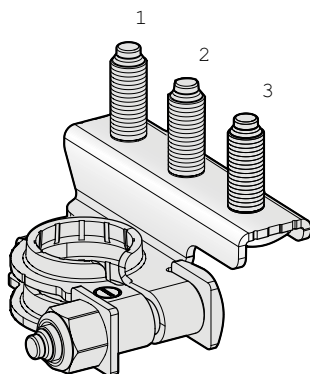

1

IMG	DESCRIPTION	POLARITY	SCREW 1	SCREW 2	SCREW 3	MATERIAL	MATERIAL THICKNESS mm	P/N BOX WITH NUTS	MOQ	P/N BULK	MOQ
1	M686DX	+	M6	M8	M6	CuZn-Sn	1,5	1507701	10	1507700	200
	M686DX	-	M6	M8	M6	CuZn-Sn	1,5	1507704	10	1507705	250
	M666DX	+	M6	M6	M6	CuZn-Sn	1,5			1507703	200
	M666DX	-	M6	M6	M6	CuZn-Sn	1,5			1507707	220
	M666SX	+	M6	M6	M6	CuZn-Sn	1,5			1507708	220
	M666SX	-	M6	M6	M6	CuZn-Sn	1,5			1507736	200
	M080SX	+	/	M8	/	CuZn-Sn	1,5			1507760	250
	M606DX	+	M6	/	M6	CuZn-Sn	1,5			1507772	250
	M606SX	+	M6	/	M6	CuZn-Sn	1,5			1507771	250
	M868DX	+	M8	M6	M8	CuZn-Sn	1,5			1507790	200
	M868SX	+	M8	M6	M8	CuZn-Sn	1,5			1508001	180

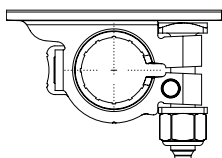

DX

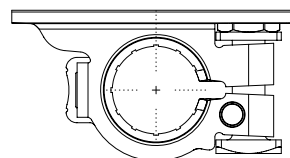

SX

DOUBLE RING

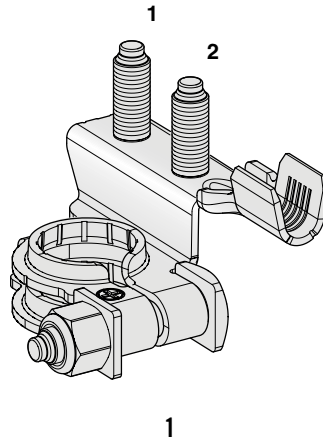

IMG	DESCRIPTION	POLARITY	SCREW 1	SCREW 2	WIRE SECTION mm ²	MATERIAL	MATERIAL THICKNESS mm	P/N BULK	MOQ
1	M66DX	+	M6	M6	10÷20	CuZn-Sn	1,3	1507800	200
	M66DX	+	M6	M6	25÷40	CuZn-Sn	1,3	1507820	200
	M66DX	-	M6	M6	25÷40	CuZn-Sn	1,3	1507875	200

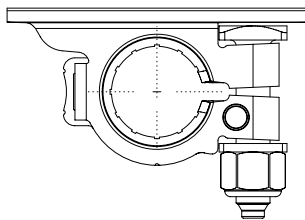

DX

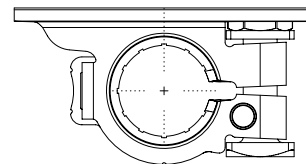

SX